

11-716KVC / 11-718KVC Start-All Wiring Diagram

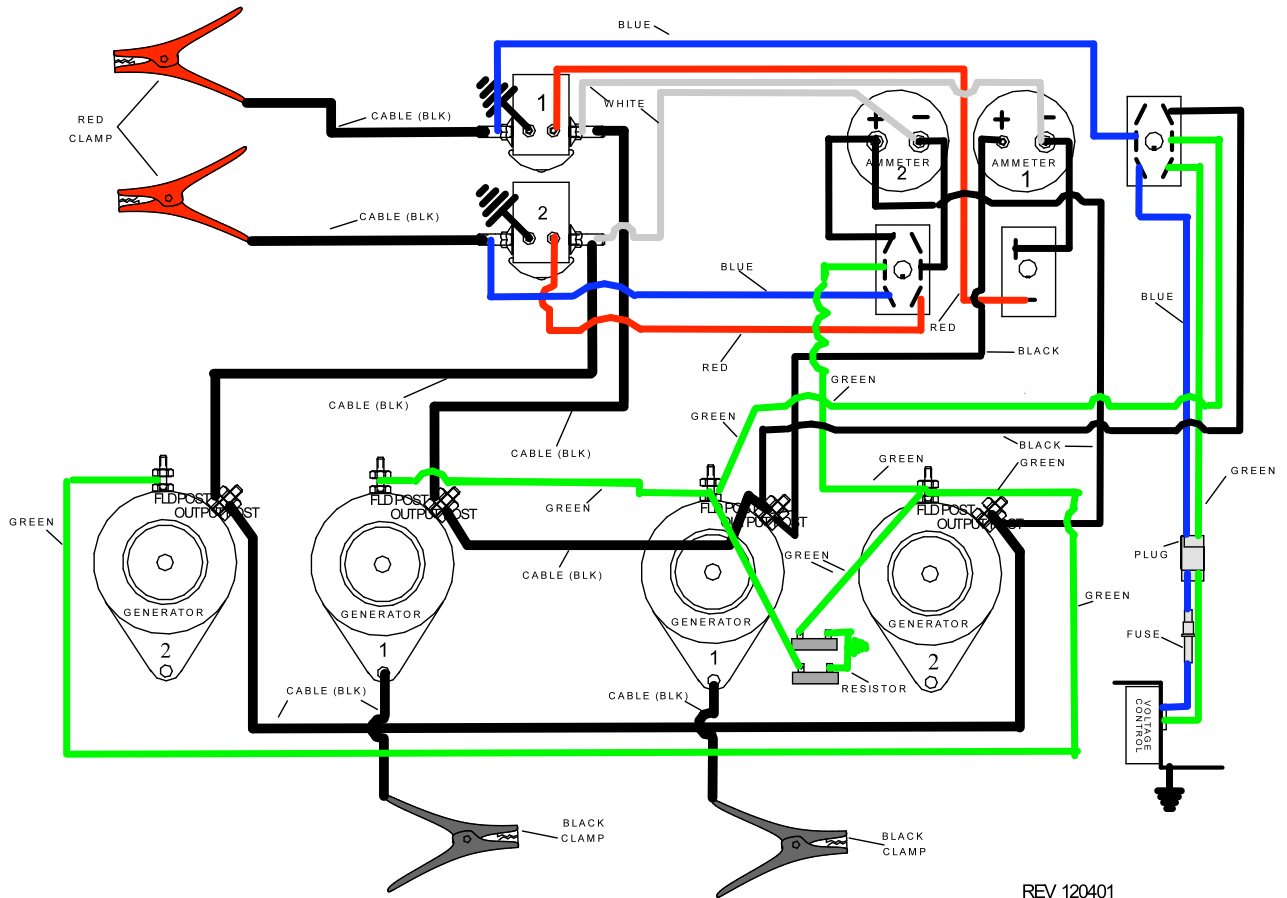

PARTS BREAKDOWN

- 70-628 V Belt – Generator
- 70-408 V Belt – Generator
- 70-437 Cable Assembly with Clamps, 2 ga. – 30 ft.
- 70-412 Engine Pulley – 4 Groove
- 79-375S Generator – Case Ground
- 70-447S Ammeter, 300-0-300
- 70-070S Red Clamp w/hardware
- 70-071S Black Clamp w/hardware
- 77-181S Solenoid
- 71-210 Starter Cable Assembly
- 77-321S Resistor Assembly
- 78-129 Latch Assembly, Hood
- 70-612S Switch Assembly (wires: 1 red, 1 black)
- 70-613S Switch Assembly (wires: 2 blue, 2 green, 1 black)
- 70-480S Switch assembly (wires: 2 black, 1 green, 1 blue, 1 red)
- 70-600-K Voltage Control / Regulator
- 61-800 12 volt Single Cable Upgrade Kit
- 61-803 12/24 volt Single Cable Upgrade Kit

tesstools.net

7.1.2011, KLK

800 397 7553

General Troubleshooting Steps for START•ALL Models

General

Inspect the cable/clamp assembly. Look for cuts, abrasions or breaks in the cable. Check for worn jaws on clamp ends. Check for excessive corrosion on all terminal end connections.

Check for proper belt tension, belts should deflect approximately 3/8" under light finger pressure.

Testing of Starting Unit

The output voltage of any starting unit with voltage controls may be tested by simply connecting a voltmeter to the large alligator clamps and then energizing. A very old unit with no voltage controls requires a battery be connected to the large alligator clamps to measure output voltage. Any 12/24 volt single cable machine that has an energize button requires a battery be connected to the starter on the gasoline engine. This provides necessary power to the energize circuit.

Voltage Control-70-600 (older style-has 2 wires)

Start All's have one or two voltage controls depending on the Model. Some very old models do not have any voltage controls. Locate the fuse holder coming from the back of each voltage control. Check for an open fuse, if fuse is open; replace it with a MDL12 fuse. If a MDL12 is not available, a 15 amp AGC fuse may be used.

If the fuse is not bad, disconnect the black two wire connector plug from each voltage control. Short the two wires together in the connector end coming from the switch (essentially connecting the green and blue wires together). If the unit has two voltage controls you only need to short the wires in one connector. This bypasses the voltage control(s). If the Start All works normally with the voltage control(s) bypassed, replace the voltage control modules.

Voltage Control-890-635 or 70-635 (newer style-has 6 wires)

Check fuse on the orange wire. Replace with a 30 Amp if the fuse is open. If the fuse is not open proceed as follows: Place a jumper wire across the field and armature terminals on any generator. The field terminal is smaller and has green wires attached. The armature terminal is larger and has heavy gauge wires attached. Place another jumper wire on a brown wire of any solenoid. The other end of the jumper wire should go to a clean contact area on the frame of the unit. Start and run the unit at 3/4 throttle. With the boosting switch off and the jumper cables disconnected, move the switch to 12V or ON. If the volt meter reads less than 12 volts, remove the jumper wires and proceed to test switches, solenoids, and generators. If the volt meter reads 12 volts or above, replace the voltage control. **NOTE: Using the Start All for boosting with the voltage control bypassed should be avoided due to the possibility of excessive voltage being created.**

Solenoid 77-181

Remove all wires from each solenoid you are testing. Apply 12 volt power to the small studs on each solenoid. The solenoid should engage and you can hear the contacts closing. With power still applied to the small terminals on the solenoid, measure the resistance between the large terminals. The reading should be near zero ohms. If the solenoids do not engage or if the reading between the large terminals is high the solenoid should be replaced.

It is also possible to have a shorted solenoid, with no power applied to the solenoid, measure the resistance between the large terminals. The reading should be open. If the reading is near zero ohms replace the solenoid. Note: A shorted solenoid will allow the Start All to function but there will be significant arcing when the cables are removed from a battery.

Generators

Inspect the generator for a solder ring or solder flakes or drops inside the generator housing just behind the brushes. If a ring of solder is found near the brush plate the generator needs to be replaced; the generators have been overheated. If no solder ring is found each generator needs to be tested.

Remove all wires from the generators and label them for re-installation. Install a bypass lead between the field post (small terminal on top of generator) and armature post (large terminal on top of generator). Attach the positive probe from a volt meter to the armature post and the negative probe to a good ground connection (such as a generator mounting bolt). With the engine at full throttle the voltage should read 22-28 volts on the volt meter. If the voltage reads below 22 check the brushes for excessive wear or increase full throttle stop. Brush length should be a minimum of 1/2". If brushes are less than 1/2", replace the brushes. If little or no voltage is present replace or rebuild the generator. Test the remaining generators by following the above steps for each generator. If all generators perform satisfactorily, reconnect the wires to each of the generators.

NOTE: When testing a 79-406 Isolated ground generator the stud on the bottom of the generator must be grounded by running a wire from the stud to a good ground connection (such as a generator mounting bolt). These isolated generators are only used on 12/24V single cable starting units.

800 397 7553

General Troubleshooting Steps for START•ALL Models

General

Inspect the cable/clamp assembly. Look for cuts, abrasions or breaks in the cable. Check for worn jaws on clamp ends. Check for excessive corrosion on all terminal end connections.

Check for proper belt tension, belts should deflect approximately 3/8" under light finger pressure.

Testing of Starting Unit

The output voltage of any starting unit with voltage controls may be tested by simply connecting a voltmeter to the large alligator clamps and then energizing. A very old unit with no voltage controls requires a battery be connected to the large alligator clamps to measure output voltage. Any 12/24 volt single cable machine that has an energize button requires a battery be connected to the starter on the gasoline engine. This provides necessary power to the energize circuit.

Voltage Control-70-600 (older style-has 2 wires)

Start All's have one or two voltage controls depending on the Model. Some very old models do not have any voltage controls. Locate the fuse holder coming from the back of each voltage control. Check for an open fuse, if fuse is open; replace it with a MDL12 fuse. If a MDL12 is not available, a 15 amp AGC fuse may be used.

If the fuse is not bad, disconnect the black two wire connector plug from each voltage control. Short the two wires together in the connector end coming from the switch (essentially connecting the green and blue wires together). If the unit has two voltage controls you only need to short the wires in one connector. This bypasses the voltage control(s). If the Start All works normally with the voltage control(s) bypassed, replace the voltage control modules.

Voltage Control-890-635 or 70-635 (newer style-has 6 wires)

Check fuse on the orange wire. Replace with a 30 Amp if the fuse is open. If the fuse is not open proceed as follows: Place a jumper wire across the field and armature terminals on any generator. The field terminal is smaller and has green wires attached. The armature terminal is larger and has heavy gauge wires attached. Place another jumper wire on a brown wire of any solenoid. The other end of the jumper wire should go to a clean contact area on the frame of the unit. Start and run the unit at 3/4 throttle. With the boosting switch off and the jumper cables disconnected, move the switch to 12V or ON. If the volt meter reads less than 12 volts, remove the jumper wires and proceed to test switches, solenoids, and generators. If the volt meter reads 12 volts or above, replace the voltage control. **NOTE: Using the Start All for boosting with the voltage control bypassed should be avoided due to the possibility of excessive voltage being created.**

Solenoid 77-181

Remove all wires from each solenoid you are testing. Apply 12 volt power to the small studs on each solenoid. The solenoid should engage and you can hear the contacts closing. With power still applied to the small terminals on the solenoid, measure the resistance between the large terminals. The reading should be near zero ohms. If the solenoids do not engage or if the reading between the large terminals is high the solenoid should be replaced.

It is also possible to have a shorted solenoid, with no power applied to the solenoid, measure the resistance between the large terminals. The reading should be open. If the reading is near zero ohms replace the solenoid. Note: A shorted solenoid will allow the Start All to function but there will be significant arcing when the cables are removed from a battery.

Generators

Inspect the generator for a solder ring or solder flakes or drops inside the generator housing just behind the brushes. If a ring of solder is found near the brush plate the generator needs to be replaced; the generators have been overheated. If no solder ring is found each generator needs to be tested.

Remove all wires from the generators and label them for re-installation. Install a bypass lead between the field post (small terminal on top of generator) and armature post (large terminal on top of generator). Attach the positive probe from a volt meter to the armature post and the negative probe to a good ground connection (such as a generator mounting bolt). With the engine at full throttle the voltage should read 22-28 volts on the volt meter. If the voltage reads below 22 check the brushes for excessive wear or increase full throttle stop. Brush length should be a minimum of 1/2". If brushes are less than 1/2", replace the brushes. If little or no voltage is present replace or rebuild the generator. Test the remaining generators by following the above steps for each generator. If all generators perform satisfactorily, reconnect the wires to each of the generators.

NOTE: When testing a 79-406 Isolated ground generator the stud on the bottom of the generator must be grounded by running a wire from the stud to a good ground connection (such as a generator mounting bolt). These isolated generators are only used on 12/24V single cable starting units.

800 397 7553